

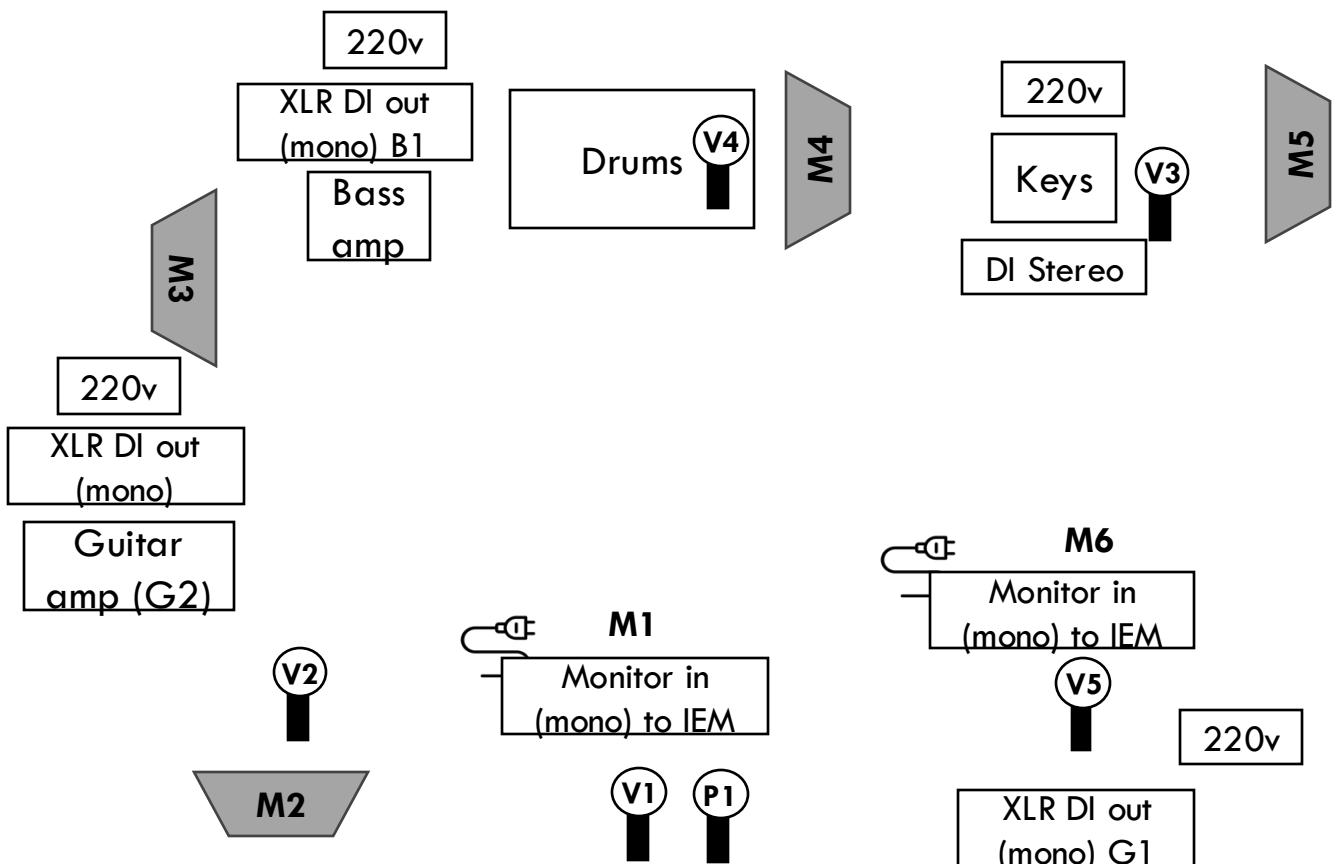

Line up band

Name	Instrument
Patrick	Lead Vocal (V1), Percussion (P1)
Eelco	Rhythm guitar (G2), en Lead/Backing Vocal (V2)
Bas	Keys (K1) en Backing Vocal (V3)
Jago	Drums (D1) en Backing Vocal (V4)
Rob	Lead guitar (G1) en Backing Vocal (V5)
Simon	Bass guitar (B1)

Stage plot band



Channel list

CH	Instrument	Preferences/notes	Split for CLB monitor mix
1	Lead Vocal (V1)	Shure SM58 (wireless)	1
2	Lead Vocal/Backing (V2)	Shure SM58	2
3	Backing Vocal (V3)	Shure SM58	3
4	Backing Vocal (V4)	Shure SM58	4
5	Backing Vocal (V5)	Shure SM58	5
6	Guitar 1 (XLR out)	Kemper mono DI out (0 db)	6
7	Guitar 2 (XLR out)	XLR DI out from amp	7
8	Keys 1 left	DI needed	8
9	Keys 1 right	DI needed	9
10	Bass (XLR out)	XLR DI out from amp	10
11	Kick	Shure beta 52/audix 6	11
12	Snare	Shure SM57	-
13	Side Snare	Shure SM57	-
14	Hi-Hat	Small diaphragm condenser	-
15	Tom 1	Sennheiser E604/804	-
16	Tom 2	Sennheiser E604/804	-
17	Tom 3	Sennheiser E604/804	-
18	Overhead Left	Small diaphragm condenser	-
19	Overhead Right	Small diaphragm condenser	-
20	Percussion (P1)	SM 57	-

In case of CLB arranging the monitor mix please provide 1 aux channel to CLB monitor mixer with channels 12-19.

Monitor Mix

	M1	M2	M3	M4	M5	M6
	Patrick	Eelco	Si	Jago	Bas	Rob
Vocals 1	+++	++	++	++	++	++
Vocals 2	++	+++	-	+	+	+
Vocals 3	++	+	-	+	+++	+
Vocals 4	++	+	-	+++	+	+
Vocals 5	++	++	-	+	+	+++
Guitar 1	++	++	++	++	++	++
Guitar 2	+	++	-	+	+	+
Bass	+	-	+++	+	+	++
Keys	++	+	++	++	+++	++
Drums	+	-	++	++	-	++
Percussion	+	+	+	+	+	+

Notes

The band will bring their own backline:

- Instruments
- Drum kit
- Amplifier (1 x elec. Guitar, 1 x bass)

The venue will arrange

- Mic stands, power, backstage room, monitors and mon. engineer, light set, PA system.

Option:

- It is possible to manage our own monitor mix with use of 4 powered wedges and sufficient XLR cables arranged by the venue. Channels 1-11 need to be split or Club Le Bon can split them. In that case FOH will receive all channels (including vocals) at line level.

Please note: band will NOT bring FOH mixer or light tech.

Patrick (Lead Vocals) and Rob (G1) will use in ear monitoring.

Preferreably arranged by the venue otherwise will bring their own.

Hospitality rider

- Some small bottles of water would be appreciated.

Thank you for your cooperation! Is something not possible, present or are there questions? Then please contact us. This rider is intended to make the collaboration as smooth as possible.